

AGENDA

COUNCIL MEETING

Tuesday, June 25, 2019

5:30 P.M.

CITY HALL COUNCIL CHAMBERS

I. CALL TO ORDER:

II. OPEN FORUM: This is a time for any concerned citizen to speak to the Council on an item that is not on the agenda.

III. CONSENT ITEMS:

- A. 6/11/19 regular Council minutes.
- B. Consider approval for fireworks permit for Terry Semke at 1202 S Grimmell Rd.
- C. Coaches Corner, Wild Rose Jefferson, LLC, Class C Liquor License (commercial).

IV. NEW BUSINESS:

- A. Consider resolution awarding sale and authorizing issuance of General Obligation Corporate Purpose Bonds, Series 2019.
- B. Consider approval of plat of survey to sell parcel A of Lot 1 of Lot A, Country Club Estates.
- C. Consider resolution setting date for public hearing on proposed 2019 Amendment to the Jefferson Urban Revitalization Plan.
- D. Consider resolution setting public hearing for Status of Funded Activities for the Jefferson CDBG Owner Occupied Rehabilitation program.
- E. Consider approval of resolution consenting to assignment of Trustee agent agreements.
- F. Consider approval of third reading of an ordinance to increase the compensation of Council members.
- G. Consider approval of third reading of an ordinance to increase the compensation of the Mayor.
- H. Presentation of equipment and containers for automated residential trash collection.
- I. Consider approval to purchase equipment and containers for automated residential trash collection.

V. REPORTS:

- A. Mayor
- B. Engineer
- C. City Clerk
- D. Attorney
- E. City Administrator
- F. Council & Committees

VI. ADJOURN.

AGENDA SUMMARY

DATE 6/25/19

NEW BUSINESS

- A. **Consider resolution awarding sale and authorizing issuance of General Obligation Corporate Purpose Bonds, Series 2019.** The sale of the bonds is scheduled to occur on Tuesday June 25, 2019. The City's financial advisor, Tim Oswald, will be at the meeting to discuss the sale.
- B. **Consider approval of plat of survey to sell parcel A of Lot 1 of Lot A, Country Club Estates.** Attached is a plat of survey request.
- C. **Consider resolution setting date for public hearing on proposed 2019 Amendment to the Jefferson Urban Revitalization Plan.**
- D. **Consider resolution setting public hearing for Status of Funded Activities for the Jefferson CDBG Owner Occupied Rehabilitation program.** Required hearing for the program that is administered by Region XII.
- E. **Consider approval of resolution consenting to assignment of Trustee agent agreements.** Bankers Trust has been handling Jefferson's Corporate Trust business for many years by performing the administration of bonds that are sold as well as the cities Trustee, Escrow Agent and/or Paying Agent for our bond sales and has for many years. The Bankers Trust Corporate Trust business has accepted an offer from UMB Bank, n.a. to acquire their Corporate Trust business. This resolution would approve a Notice of Assignment from Bankers Trust to UMB Bank, n.a. to ensure a seamless transaction and uninterrupted service of our business with them.
- F. **Consider approval of third reading of an ordinance to increase the compensation of Council members.** The current ordinance provides for \$30 per meeting not to exceed \$1,000 per year and has been in place since 2002. The amendment would provide for \$60 per meeting not to exceed \$2,000 per year.
- G. **Consider approval of third reading of an ordinance to increase the compensation of the Mayor.** The current ordinance provides for \$200 per month. The amendment would increase the amount to \$400 per month.
- H. **Presentation of equipment and containers for automated residential trash collection.** Attached is information on the trash truck and containers along with a schedule to implement the change in collection by September 2, 2019.
- I. **Consider approval to purchase equipment and containers for automated residential trash collection.** Attached are the prices for the mechanical arm trash collection truck, the bins and a rear end collection truck.

COUNCIL MEETING
JUNE 11, 2019
5:30 P.M.

PRESENT: Ahrenholtz, Jackson, Sloan, Wetrich, Gordon
ABSENT: None

Mayor Berry presided.

During open forum James Lorenzen voiced his concerns on the hay field by 507 N Grimmell not being cut and the snakes in his yard. Also his wife got hurt downtown during Bell Tower Festival by tripping on the sidewalk. He reported it to Mike Palmer on June 10, 2019, the claim has been sent to our insurance company.

On motion by Sloan second by Gordon, the Council approved the following consent agenda: 5/28/19 Council Minutes, payment of monthly bills from City funds, Cigarette/Tobacco/Vapor Permit July 1, 2019 – July 30, 2020 MOES MART #14, Hy-Vee Market Café, Class C Liquor License (Commercial), Hotel/Motel grant for \$350 to Jefferson Matters: Main Street for event planner.

AYE: Jackson, Ahrenholtz, Wetrich, Gordon, Sloan
NAY: None

This was the time and place for a public hearing on the general obligation loan agreement in amount not to exceed \$243,000 for construction of ten-foot wide "shared use path" along Central Avenue from Iowa Highway 4 west to Walnut Street. The Mayor called for any comments and questions were asked on what side of street and how long before school will build to it. These items have not been decided yet. On motion by Ahrenholtz, second by Jackson, the Council closed the public hearing.

AYE: Wetrich, Gordon, Jackson, Sloan, Ahrenholtz
NAY: None

RESOLUTION NO. 27-19

On motion by Sloan second by Wetrich, the Council approved Resolution No. 27-19, a resolution consenting to assignment of Trustee Agent Agreements; Escrow Agent Agreements; and/or Paying Agent and Registrar and Transfer Agent Agreements setting date June 25, 2019 5:30pm for GO bond sale of \$2,540,000 in bonds and authorizing use of preliminary official statement.

AYE: Sloan, Ahrenholtz, Gordon, Jackson, Wetrich
NAY: None

This was the time and place for a public hearing on 243rd Street for airport runway extension project. Berry called for any oral or written comments and there were none. On motion by Gordon, second by Jackson, the Council closed the public hearing.

AYE: Wetrich, Ahrenholtz, Jackson, Sloan, Gordon
NAY: None

RESOLUTION NO. 28-19

On motion by Jackson second by Wetrich, the Council approved Resolution No. 28-19, a resolution approving Detailed Plans and Specification, Form of Contract, and Estimate of Cost for Relocate Greene County Road 243rd Street Project.

AYE: Gordon, Sloan, Wetrich, Jackson, Ahrenholtz
NAY: None

On motion by Ahrenholtz, second by Gordon, the Council approved an application to the FAA for \$648,197 (100% grant) for construction of the Relocation of 243rd Street project.

AYE: Sloan, Jackson, Ahrenholtz, Wetrich, Gordon

NAY: None

On motion by Wetrich, second by Gordon, the Council approved the appointment of Jerry Roberts as Library Trustee.

AYE: Ahrenholtz, Gordon, Jackson, Wetrich, Sloan

NAY: None

The Council had a discussion of extension of general three year tax abatement and establishing multi-family residential 10 year tax abatement. This will be put on next agenda.

On motion by Jackson second by Gordon, the Council approved placing on 2nd reading an ordinance increasing per meeting compensation for City Council meetings from \$30.00/mtg to \$60.00/mtg.

AYE: Ahrenholtz, Jackson, Sloan, Wetrich, Gordon

NAY: None

On motion by Sloan, second by Wetrich, the Council approved placing on 2nd reading an ordinance increasing per month compensation for Mayor from \$200/mo. to \$400/mo.

AYE: Gordon, Sloan, Wetrich, Ahrenholtz, Jackson

NAY: None

RESOLUTION NO. 29-19

On motion by Jackson, second by Gordon, the Council approved Resolution No. 29-19, a resolution approving twelfth amendment to City Administrator Employment Agreement extending the term of the Employment Agreement through June 30, 2020 and adjusting City Administrators' salary to \$101,296.00/yr effective July 1, 2019.

AYE: Wetrich, Sloan, Ahrenholtz, Jackson, Gordon

NAY: None

Mary Weaver & John Turpin gave update on Thomas Jefferson Gardens.

The following bills were approved for payment from City funds:

ABC PEST CONTROL	PEST CONTR	290.00
ACCESS SYSTEMS	RN STAPLES	108.99
ACCESS SYSTEMS INC	RN CPIER LSE	564.23
ACCESS SYSTEMS LEASING	LB CPIER LSE	865.73
ACCO UNLIMITED CORP	WA CHEM	3,879.20
ACTION GRAPHICS & DESIGNS	GCRSE SIGN	57.00
ACUSHNET COMPANY	GCRSE MERCH	1,739.53
AFLAC	AFLAC INS W/H	111.76
AFSCME/IOWA COUNCIL 61	UNION DUES	86.36
AG SOURCE LAB	WA TSTG	183.50
ALEX AIR APPARATUS INC	JFD SHIELDS	115.00
ALEXANDRA M. RATLIFF	WA DEP REF	85.32
ANGIE GIBSON	WA DEP REF	29.02
AUSTIN SADDORIS	WA DEP REF	108.25
BAKER & TAYLOR INC.	LB MOVIES	2,156.13
BAM	LB BOOKS	520.82

APPLICATION FOR
FIREWORKS PERMIT

The undersigned,

Name: TERRY SEMKE

Address: 1202 S. GRIMMELL RD
JEFFERSON, IA 50129

Telephone: 515-386-8286 OR 515-370-1798

hereby applies pursuant to the provisions of the Iowa Code for a permit
to display fireworks at 1202 S. GRIMMELL RD

such permit to be effective from July 3 to July 10,
to _____ . If this application is approved
the undersigned agrees to faithfully observe all applicable laws
governing the use of fireworks.

Date: 6-14-19

Terry Semke



CERTIFICATE OF LIABILITY INSURANCE

SEMKET1

OP ID: JU

DATE (MM/DD/YYYY)

06/21/2019

THIS CERTIFICATE IS ISSUED AS A MATTER OF INFORMATION ONLY AND CONFERS NO RIGHTS UPON THE CERTIFICATE HOLDER. THIS CERTIFICATE DOES NOT AFFIRMATIVELY OR NEGATIVELY AMEND, EXTEND OR ALTER THE COVERAGE AFFORDED BY THE POLICIES BELOW. THIS CERTIFICATE OF INSURANCE DOES NOT CONSTITUTE A CONTRACT BETWEEN THE ISSUING INSURER(S), AUTHORIZED REPRESENTATIVE OR PRODUCER, AND THE CERTIFICATE HOLDER.

IMPORTANT: If the certificate holder is an ADDITIONAL INSURED, the policy(ies) must be endorsed. If SUBROGATION IS WAIVED, subject to the terms and conditions of the policy, certain policies may require an endorsement. A statement on this certificate does not confer rights to the certificate holder in lieu of such endorsement(s).

PRODUCER Unger Insurance, Ltd. 103 East Lincolnway/PO Box 191 Jefferson, IA 50129 Jim Unger		CONTACT NAME: Jim Unger PHONE (A/C, No, Ext): 515-386-4156 E-MAIL ADDRESS: FAX (A/C, No):	
INSURED Terry L. Semke 1202 S. Grimmell Jefferson, IA 50129		INSURER(S) AFFORDING COVERAGE INSURER A: Employers Mutual Companies NAIC # 21415 INSURER B: INSURER C: INSURER D: INSURER E: INSURER F:	

COVERAGES

CERTIFICATE NUMBER:

REVISION NUMBER:

THIS IS TO CERTIFY THAT THE POLICIES OF INSURANCE LISTED BELOW HAVE BEEN ISSUED TO THE INSURED NAMED ABOVE FOR THE POLICY PERIOD INDICATED. NOTWITHSTANDING ANY REQUIREMENT, TERM OR CONDITION OF ANY CONTRACT OR OTHER DOCUMENT WITH RESPECT TO WHICH THIS CERTIFICATE MAY BE ISSUED OR MAY PERTAIN, THE INSURANCE AFFORDED BY THE POLICIES DESCRIBED HEREIN IS SUBJECT TO ALL THE TERMS, EXCLUSIONS AND CONDITIONS OF SUCH POLICIES. LIMITS SHOWN MAY HAVE BEEN REDUCED BY PAID CLAIMS

INSR LTR	TYPE OF INSURANCE	ADDL INSD	SUBR WVD	POLICY NUMBER	POLICY EFF (MM/DD/YYYY)	POLICY EXP (MM/DD/YYYY)	LIMITS
A	COMMERCIAL GENERAL LIABILITY <input type="checkbox"/> CLAIMS-MADE <input type="checkbox"/> OCCUR <input checked="" type="checkbox"/> PERSONAL LIAB			28H7802	12/12/2018	12/12/2019	EACH OCCURRENCE \$ 300,000 DAMAGE TO RENTED PREMISES (Ea occurrence) \$ MED EXP (Any one person) \$ PERSONAL & ADJ INJURY \$ GENERAL AGGREGATE \$ PRODUCTS - COMPI/OP AGG \$ OTHER \$
	GEN'L AGGREGATE LIMIT APPLIES PER: <input type="checkbox"/> POLICY <input type="checkbox"/> PRO-JECT <input type="checkbox"/> LOC OTHER						
	AUTOMOBILE LIABILITY <input type="checkbox"/> ANY AUTO <input type="checkbox"/> ALL OWNED AUTOS <input type="checkbox"/> HIRED AUTOS <input type="checkbox"/> SCHEDULED AUTOS <input type="checkbox"/> NON-OWNED AUTOS						COMBINED SINGLE LIMIT (Ea accident) \$ BODILY INJURY (Per person) \$ BODILY INJURY (Per accident) \$ PROPERTY DAMAGE (Per accident) \$ OTHER \$
	UMBRELLA LIAB <input type="checkbox"/> OCCUR EXCESS LIAB <input type="checkbox"/> CLAIMS-MADE DED \$ RETENTION \$						EACH OCCURRENCE \$ AGGREGATE \$ OTHER \$
	WORKERS COMPENSATION AND EMPLOYERS' LIABILITY ANY PROPRIETOR/PARTNER/EXECUTIVE OFFICER/MEMBER EXCLUDED? (Mandatory in NH) If yes, describe under DESCRIPTION OF OPERATIONS below	Y/N	N/A				PER STATUTE OTH-ER E.L. EACH ACCIDENT \$ E.L. DISEASE - EA EMPLOYEE \$ E.L. DISEASE - POLICY LIMIT \$

DESCRIPTION OF OPERATIONS / LOCATIONS / VEHICLES (ACORD 101, Additional Remarks Schedule, may be attached if more space is required)

CERTIFICATE HOLDER

CANCELLATION

CITY001 City of Jefferson 220 N. Chestnut Jefferson, IA 50129	SHOULD ANY OF THE ABOVE DESCRIBED POLICIES BE CANCELLED BEFORE THE EXPIRATION DATE THEREOF, NOTICE WILL BE DELIVERED IN ACCORDANCE WITH THE POLICY PROVISIONS. AUTHORIZED REPRESENTATIVE Jim Unger
--	--

APPLICATION FOR APPROVAL OF PLAT OF SURVEY

TO: City Council of Jefferson

The undersigned owner(s) of the land described in the attached plat of survey request the City Council of the City of Jefferson to approve the division of land reflected in the attached plat of survey pursuant to Section 166.22 of the Code of Ordinances of the City of Jefferson. The following information is submitted in support of this application:

1. A pre-application conference regarding this proposed subdivision was held with the City Administrator on 5/17/19.

2. A copy of a plat of survey prepared by Robert B. Bills, an Iowa registered land surveyor, dated 05/08/2019, showing the land proposed to be divided is attached to this application.

3. The purpose of this proposed division is: Sell Parcel A OF LOT 1 OF LOTA TO JOHN AND NANCY GERKEN

4. The name(s), address(es) and telephone number(s) of all the owners of the land described in the attached plat are as follows:

Douglas and Jean Tucker
500 W Greenwood Road, Jefferson

5. The names and addresses of all adjoining property owners are set forth below, and the approximate locations of their properties are shown on the attached plat.

John and Nancy Gerken
502 W. Greenwood Rd, Jefferson

6. (a) The existing zoning classification of the property covered by the plat is RM-3. (There is no pending plan or proposal to change this zoning classification./It is proposed that the zoning classification of this property be changed to NONE.)

(b) The zoning classification(s) for the adjoining properties is/are as follows: RM-3. (There is no pending plan or proposal to change any zoning classification for any of the adjoining properties./It is proposed that the zoning classification of adjoining property be changed to NONE.)

7. (Check applicable paragraph:)

There are no structures located on the property proposed to be divided.

There are one or more structures located on the property proposed to be divided, and the location of such structures and their distance from existing and proposed boundary lines has been shown by a registered land surveyor either on the attached plat or on a separate drawing attached to this application.

8. All existing and proposed public streets and roads, all public water and sanitary and storm sewer lines, and all gas and electrical services in relation to the property proposed to be divided have been described by a registered land surveyor either on the attached plat or on a separate drawing attached to this application. If any parcel shown on the attached plat does not have direct access to any such services, then it is proposed that access to such services be obtained as follows:

If any private easements are proposed, copies of the same will be provided upon request.

The undersigned acknowledge that they have reviewed the foregoing application and represent and warrant that the information set forth above is true and accurate. This application is being submitted in quadruplicate.

Date: May 22, 2019

Douglas Tucker

Jean A. Tucker

APPROVAL RECOMMENDED/NOT RECOMMENDED

City Engineer Date

APPROVAL RECOMMENDED/NOT RECOMMENDED

City Administrator Date

INDEX LEGEND	PLAT OF SURVEY
COUNTY: GREENE	
DESIGNATION: PARCEL "A" OF LOT 1 OF LOT A COUNTRY CLUB LOT	
LOCATION: N1/2 SE1/4 SECTION 18, T83N, R30W	
SITE ADDRESS: 500 W. GREENEWOOD ROAD, JEFFERSON, IA 50129	
OWNER: DOUGLAS AND JEAN A. TUCKER	
SURVEY REQUESTED BY: JOHN GERKEN	
SURVEYOR: ROBERT B. BILLS	

PREPARED BY AND RETURN TO: ROBERT B. BILLS CENTRAL IOWA SURVEYING, LLC P.O. BOX 67 JEFFERSON, IOWA 50129 (515)370-2399

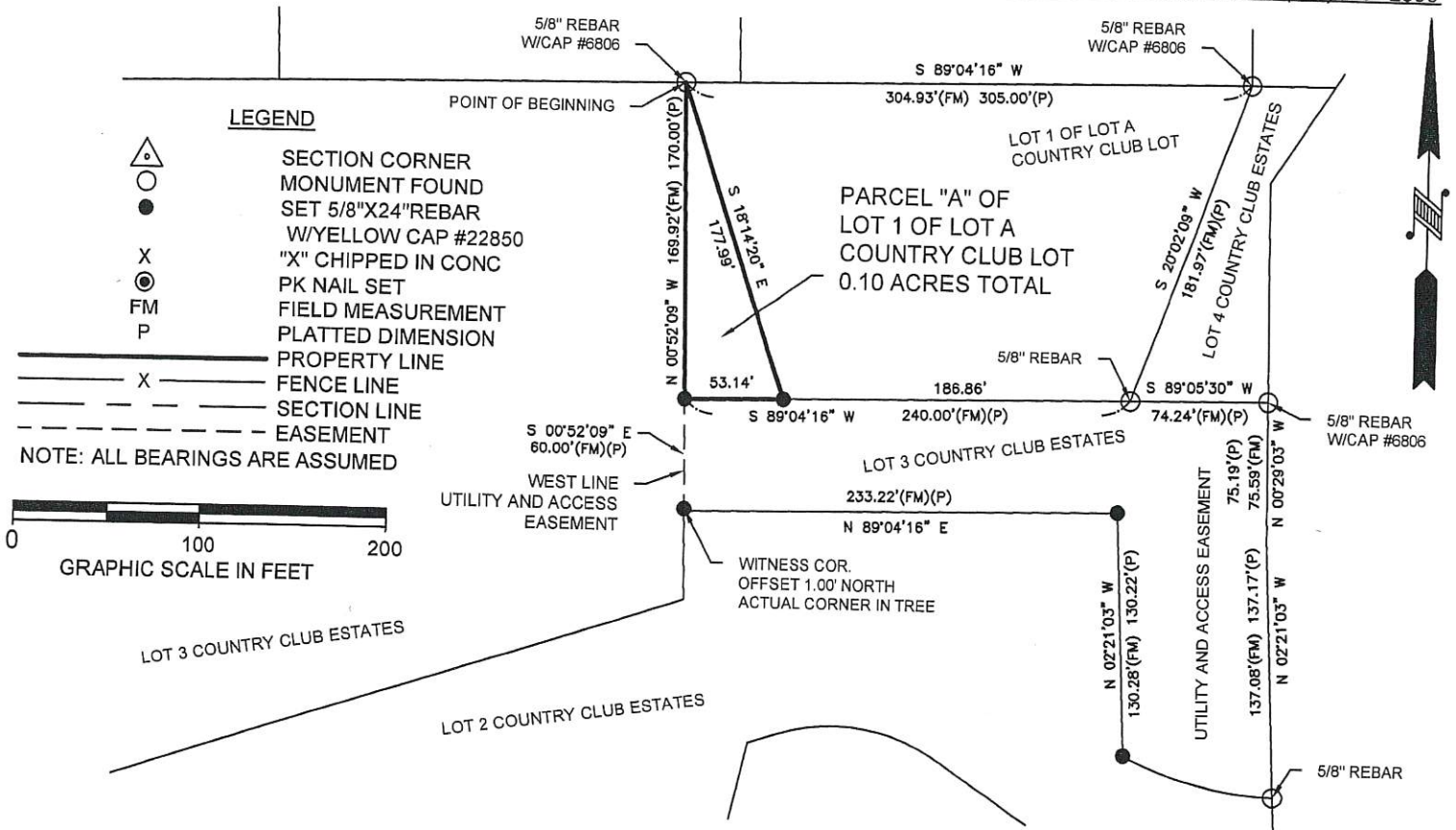

FIELD NOTES:

A TRACT OF LAND LOCATED IN LOT 1 OF LOT A OF COUNTRY CLUB LOT IN THE NORTH ONE HALF OF THE SOUTHEAST QUARTER OF SECTION 18, T83N, R30W OF THE 5TH P.M., CITY OF JEFFERSON, GREENE COUNTY, IOWA RECORDED IN BOOK 116 AT PAGE 293 IN THE GREENE COUNTY RECORDER'S OFFICE BEING MORE PARTICULARLY DESCRIBED AS FOLLOWS:

BEGINNING AT THE NORTHWEST CORNER OF SAID LOT 1 OF LOT A; THENCE S18°14'20"E, A DISTANCE OF 177.99 FEET TO A POINT ON THE SOUTH LINE OF SAID LOT 1 OF LOT A; THENCE S89°04'16"W ON SAID SOUTH LINE, A DISTANCE OF 53.14 FEET TO THE SOUTHWEST CORNER OF SAID LOT 1 OF LOT A; THENCE N00°52'09"W ON THE WEST LINE OF SAID LOT 1 OF LOT A, A DISTANCE OF 169.92 FEET TO THE POINT OF BEGINNING.

THE ABOVE DESCRIBED PARCEL SHALL HEREAFTER BE KNOWN AS PARCEL "A" OF LOT 1 OF LOT A OF COUNTRY CLUB LOT IN THE NORTH ONE HALF OF THE SOUTHEAST QUARTER OF SECTION 18, T83N, R30W OF THE 5TH P.M. CITY OF JEFFERSON, GREENE COUNTY,



GENERAL NOTES:

1. CITY OF JEFFERSON UTILITY LINES (SANITARY SEWER, STORM SEWER, AND WATER) ARE ONLY GENERALLY LOCATED. UTILITY SERVICES BY OTHERS ARE NOT SHOWN. "ONE CALL" SHOULD BE CONTACTED PRIOR TO ANY CONSTRUCTION ACTIVITIES.
2. AERIAL PHOTO IS ONLY APPROXIMATED TO PROPERTY LINES.



RESOLUTION NO. _____

To fix a date of meeting for a public hearing on a proposed 2019 Amendment to the Jefferson Urban Revitalization Plan

WHEREAS, the City of Jefferson, Iowa (the “City”), pursuant to and in strict compliance with all laws applicable to the City, and in particular the provisions of Chapter 404 of the Code of Iowa (“Chapter 404”), has designated an area of the City as an urban revitalization area (the “Jefferson Urban Revitalization Area”) and has adopted an urban revitalization plan for the Jefferson Urban Revitalization Area (the “Urban Revitalization Plan”) and has approved amendments to that Plan; and

WHEREAS, pursuant to the provisions of Chapter 404, before amending the Urban Revitalization Plan, the City must publish a notice and hold a hearing; and

WHEREAS, a proposed 2019 Amendment to the Urban Revitalization Plan has been prepared and presented to the City Council for consideration, for the purpose of deleting the date on which eligibility for property tax abatement benefits would expire and increasing from three years to ten years the time period during which property classified as multiresidential would be eligible for benefits, which amendment is set forth as Exhibit A attached hereto; and

WHEREAS, it is necessary to set a date for a public hearing on the proposed 2019 Amendment to the Urban Revitalization Plan, pursuant to Chapter 404;

NOW, THEREFORE, IT IS RESOLVED by the City Council of the City of Jefferson, Iowa, as follows:

Section 1. This Council shall meet on the 9th day of July, 2019, at _____ o'clock p.m., at the Council Chambers, City Hall, at which time and place a public hearing will be held and proceedings will be instituted and action taken to approve the proposed 2019 Amendment to the Urban Revitalization Plan.

Section 2. The City Clerk is hereby directed to give notice of the proposed action, the time when and place where said meeting will be held, by publication at least once not less than seven days and not more than twenty days before said meeting in a legal newspaper of general circulation in the City. Said notice shall be in substantially the following form:

RESOLUTION NO. _____

Resolution consenting to assignment of Trustee Agent Agreements; Escrow Agent Agreements; and/or Paying Agent and Registrar and Transfer Agent Agreements

WHEREAS, the City Council of the City of Jefferson, Iowa (the "City"), has adopted certain resolutions (the "Resolutions") duly authorizing and providing for the issuance of certain bonds, notes or other obligations (collectively, the "Outstanding Obligations"); and

WHEREAS, pursuant to the Resolutions, the City appointed Bankers Trust Company, Des Moines, Iowa ("Bankers Trust"), as the registrar and paying agent for the Outstanding Obligations and approved the execution of Paying Agent and Registrar and Transfer Agent Agreements with Bankers Trust with respect to the Outstanding Obligations; and

WHEREAS, in connection with the issuance of certain Outstanding Obligations, the City may have also entered into certain Trustee Agent Agreements and/or Escrow Agent Agreements with Bankers Trust; and

WHEREAS, UMB Bank, n.a. ("UMB") will acquire the corporate trust business of Bankers Trust, and any existing Trustee Agent Agreements; Escrow Agent Agreements; and Paying Agent and Registrar and Transfer Agent Agreements (collectively, such Agreements are hereinafter referred to as the "Agreements") between the City and Bankers Trust will be assigned by Bankers Trust to UMB; and

WHEREAS, Bankers Trust and UMB have requested that the City consent to the assignment of the Agreements;

NOW, THEREFORE, It Is Resolved by the City Council of the City of Jefferson as follows:

Section 1. The City hereby consents to the assignment of the Agreements from Bankers Trust to UMB. The Mayor and the City Clerk are hereby authorized to execute such documents as may be necessary to carry out the assignment of the Agreements, including the "Acknowledgment to Assignment" that has been prepared by Bankers Trust and presented to the City.

Section 2. The effective date of the assignment of the Agreements shall be as set forth in the Acknowledgment to Assignment.

Section 3. To the extent that the City has continuing disclosure requirements pursuant to Rule 15c2-12 of the Securities Exchange Act relative to the Outstanding Obligations, the City will cause a notice of the assignment of the Agreements to be posted on the MSRB Electronic Municipal Market Access (EMMA).



NEW WAY®

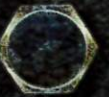

THE MOST RUGGED SIDE-LOADER ON EARTH
SIDEWINDER XTR™

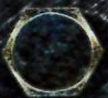

NEW WAY® SIDEWINDER™

Diagrams Represent 29-31yd Units

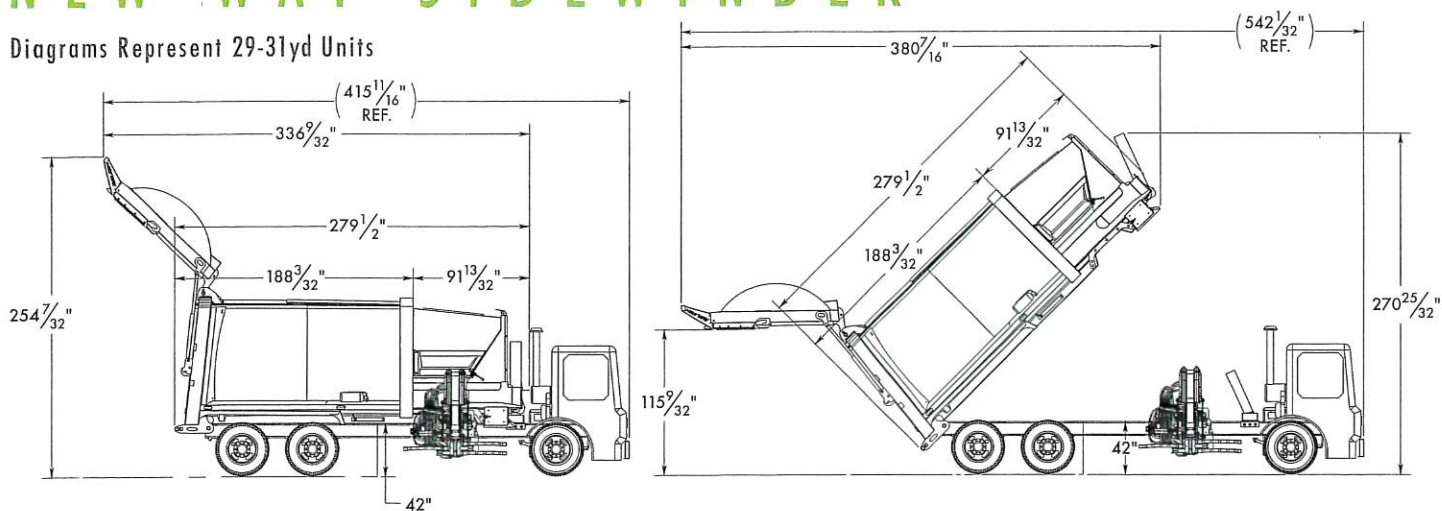

GENERAL SPECIFICATIONS

Model	22 yd ³ Dump	24 yd ³ Dump	29 yd ³ Dump	31 yd ³ Dump
Body Capacity	22 yd ³	24 yd ³	29 yd ³	31 yd ³
Body Width	96"	96"	96"	96"
Body Length	237"	247"	286"	297"
Body Height	108"	108"	108"	108"
†Raised Tailgate Height	213"	213"	213"	213"
‡Body Height (Raised)	195"	195"	229"	229"

MINIMUM CHASSIS SPECIFICATIONS

Model	22 yd ³ Dump	24 yd ³ Dump	29 yd ³ Dump	31 yd ³ Dump
* Minimum GVWR	46,000 lbs.	46,000 lbs.	64,000 lbs.	64,000 lbs.
Usable C/T Requirement	160"	160"	197"	197"

PACKER SPECIFICATIONS

Hopper Capacity	6 cubic yards
Packer Swept Volume	2 cubic yards
Packer Cycle Time	21 seconds
Ram Penetration	8.5 inches
Ram Compaction Force	75,000 lbs. @ 3,000psi

ARM SPECIFICATIONS

Arm Extension	144"
Arm Lifting Capacity	1000lbs.
# Horizontal Mast Bearings	6
Arm Cycle Time	6-8 secs.

BODY CONSTRUCTION

Roof	10 gauge: 80 k
Sides	10 gauge-AR450
Packer Panel	¼ inch AR 450
Body Floor	8 gauge AR 450
Tailgate Back	10 gauge AR 450
Tailgate Sides	10 gauge-80K
Hopper Floor/Sides	¼ inch AR 450
Ram Guide	3/8" x 3" AR400 wear strips top 1/4" Sides

HYDRAULIC SYSTEM

Oil Reservoir	70 Gal.
Oil Flow Rate	
Body	20 gpm @ 750 RPM
Arm	18 gpm @ 750 RPM
Body Operating Pressure	
22-24 yd ³ units	2500psi
29-31 yd ³ units	3000psi
Arm Operating Pressure	2000psi
Hoses	4-to-1 Burst
Return Filters	Spin-on 10 micron absolute

HYDRAULIC CYLINDER SPECIFICATIONS

Tailgate Cylinders	3" x 30" x 2"
Pack Panel Cylinders	4" x 43" x 2.5"
Gripper Cylinder	1.5" x 5" x 1"
Vertical Lift Cylinder	3" x 16" x 2"
Body Hoist Cylinder	
29-31 cu yd	6.5" x 180" 4-Stage
22-24 cu yd	6.5" x 150" 4-Stage
Horizontal Mast Cylinder	2" x 54" x 1.25"
Hopper Cover Cylinder	2" x 18" x 1.25"

STANDARD EQUIPMENT

Pack-on-the-go
 Twin 14.5" x 7" clean out doors
 Chrome cylinder rods w/scrapers
 Interlocked side access hopper door
 Nitro carbonite single hoist cylinder
 Sight gauge on reservoir tank
 Tailgate ajar alarm
 Dupont Elite paint (white)
 High grade hydraulic fluid
 Dual flat screen rear vision camera system
 Reinforced, frame-mounted arm
 In-line heavy duty grippers
 Sealed roller bearings on packer follower panels
 Ergonomic in-cab control panel and joystick
 Smooth body sidewall design
 Positive automatic tailgate lock
 Back-up alarm
 Body ajar alarm
 Hour meter
 "Arm stowed" indicator
 LED lights
 ANSI Z 245.1-2008 compliant
 Multi cycle packer

OPTIONAL EQUIPMENT

Hydraulic Hopper Cover
 300 gallon gripper
 Camera options
 Additional arm controls
 Hopper ladder
 Color paint
 Broom/Shovel racks
 Arm cycle counter
 CNG Powered

† As measured from top of truck frame. * Any Chassis sent to Scranton Manufacturing with less than the minimum guideline requirements will not be mounted. (Chassis must be capable of carrying the net weight of the body plus the weight of the refuse collected.)



Find a New Way®
 dealer near you at
www.newwaytrucks.com

SSI SCHAEFER Waste Technology Division

The ONE company that gives you everything you expect...and more.

- Highest Quality
- Best Service
- Managed Distribution & Assembly
- RFID-Enabled Cart Management



Proud supporters of



ssi-schaefer.us/waste

P. 888.262.9112



Schaefer Universal System Design Cart

Model USD is for use with standard bar-lock lifters or automated grabbers.



Body

Body

- Non-slip, textured finish on corners for grabber efficiency
- Long-lasting, integrated lid hinges
- Smooth surface inside and out for easy maintenance
- Injection molded for maximum strength and durability
- One-piece high-density polyethylene (HDPE) construction
- Built-in flexibility (M Only)



Bar

Bar

- Sealed retention bar
- Highly durable, in-molded bar supports
- Freely rotating recycled bar for less stress on cart body
- Installed by factory personnel
- Extra wall thickness in bar area for durability



Upper Attachment

Upper Attachment

- Integrated, reinforced upper attachment for semi-automated lifters
- Structurally designed per ANSI Standards



Lids

Lids

- Overlapping lip for rain protection
- Inside dripping rim to seal in odors
- 270° lid opening
- Sturdy, comfortable and safe ergonomic handles (2)

Handles

- Ergonomically designed hand grips for ease of pushing/pulling the cart
- Smooth surface with no protrusions
- 2" x 5" opening for easy gripping
- RFID Ready

Wheels & Axles

- Axle of tempered, rolled and Zink Chromate steel
- Maintenance-free bearings lubricated for life
- 10" or 12" wheels available for 95M-gallon model
- 10" wheels on 65-gallon model
- 8" wheels on 35-gallon model

Bottom

- Toe hold to ease tilting of loaded cart
- 0.375" wear strip for longer life

Colors & Marking

- Available in green, blue, brown and charcoal
- Custom colors available
- Smooth surface for hot stamping on lid and body

SCHAEFER SYSTEMS INTERNATIONAL, INC.
 P.O. Box 7009 | Charlotte, NC 28241
 Phone: 704.944.4500 | Fax: 704.944.4569
ssi-schaefer.us/waste

Manufacturing plants

Charlotte, NC
 Lodi, CA

Universal System Design Cart (measurements in inches, unless specified)

Order #	Dimensions				Wheel Diameter	Load Rating lbs. ▼	Full Truckload
	H	H Cart Body	W	D			
USD 35	38.2	35.8	22.8	22.3	8	125	1008
USD 65M	41.5	39.1	24.4	27.5	10	230	847
USD 95M	44.3	41.06	27.6	31.5	10	330	549

ANSI Z245.30 and ANSI Z245.60 Approved
 ISO 9001 Certified

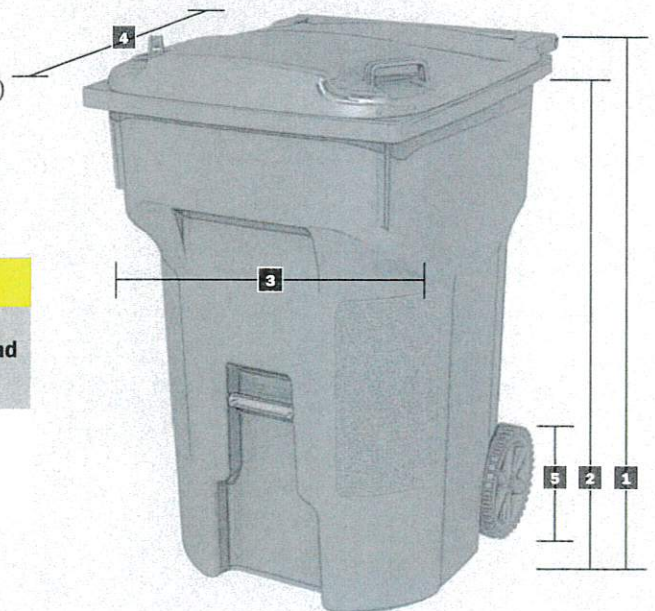

ID	Task Name	Duration	Start	Finish
TRASH TRUCK REPLACEMENT SCHEDULE				
1	Bond passes	83 edays	Tue 6/11/19	Mon 9/2/19
2	Committee reviews proposed ordinance changes	0 edays	Tue 6/11/19	Tue 6/11/19
3	Preliminary draft of ordinance sent to attorney	7 edays	Tue 6/11/19	Tue 6/18/19
4	Bonds sold	10 edays	Tue 6/11/19	Fri 6/21/19
5	Council approves purchase of truck	14 edays	Tue 6/11/19	Tue 6/25/19
6	Press Release ready	14 edays	Tue 6/11/19	Tue 6/25/19
7	Order truck	14 edays	Tue 6/11/19	Tue 6/25/19
8	Order carts	14 edays	Tue 6/11/19	Tue 6/25/19
9	Public education begins	34 edays	Tue 6/11/19	Mon 7/15/19
10	Committee reviews proposed ordinance changes	34 edays	Tue 6/11/19	Mon 7/15/19
11	Ordinance change 1st reading	35 edays	Tue 6/11/19	Tue 7/16/19
12	Spread sheet for carts completed (final)	42 edays	Tue 6/11/19	Tue 7/23/19
13	Truck delivered	50 edays	Tue 6/11/19	Wed 7/31/19
14	Training begins	58 edays	Tue 6/11/19	Thu 8/8/19
15	Ordinance change 2nd reading	62 edays	Tue 6/11/19	Mon 8/12/19
16	Carts delivered to City	63 edays	Tue 6/11/19	Tue 8/13/19
17	Carts assembled	76 edays	Tue 6/11/19	Mon 8/26/19
18	Ordinance change 3rd reading	76 edays	Tue 6/11/19	Mon 8/26/19
19	Carts placed at residential properties	77 edays	Tue 6/11/19	Tue 8/27/19
20	Truck operational	80 edays	Tue 6/11/19	Fri 8/30/19
21		83 edays	Tue 6/11/19	Mon 9/2/19



June 25, 2019
City Hall
220 N Chestnut Street
Jefferson, IA 50129

Proposal for Automated Garbage Collection

2019 Peterbilt 520 chassis with New Way Sidewinder 31 yd automated packer - \$258,977

-Estimated Delivery – August 1, 2019

2019 International HV607 chassis with New Way Cobra rear load packer - \$161,220

-Estimated Delivery – September 15, 2019

Trade Value for 2007 Sterling chassis with New Way Cobra 20 yard rear load packer - \$20,000

Assembly and Distribution of 95 gallon and 65 gallon Schaefer carts - \$114,984

-Delivery – 4 semi loads of carts will be delivered on Monday, August 26th. The assembly and distribution team will be on site at 7:00 that morning to offload the carts and begin the assembly and distribution process. The City of Jefferson will provide educational literature to the A&D team to be placed on each cart as it is delivered. A complete address list of where carts are to be delivered will be provided by the City of Jefferson prior to August 26. I anticipate assembly and distribution to be complete on Wednesday, August 28, or Thursday, August 29. Automated collection will begin the following Monday, September 2.

Total for all new equipment less the trade of the 2007 Sterling - \$515,181

Corey Schultz
Elliott Equipment Company
712-269-0329

3100 WEST 76TH STREET
DAVENPORT, IA 52806
PHONE: (563) 391-4840

CORPORATE OFFICE
4000 S.E. BEISSER DRIVE
GRIMES, IA 50111
PHONE: (515) 986-4840
FAX: (515) 986-9530

ELLIOTT SANITATION EQUIP. CO.
1245 DAWES AVENUE
LINCOLN, NE 68521
PHONE: (402) 474-4840

14001 BOTTS RD.
GRANDVIEW, MO 64030
PHONE: (816) 761-4840



3100 West 76th Street
Davenport, IA 52806
Ph: 563-391-4840

Elliott Sanitation Equip. Co.
1245 Dawes Avenue
Lincoln, NE 68521
Ph: 402-474-4840

4000 SE Beisser Drive
Grimes, IA 50111
Ph: 515-986-4840
Fx: 515-986-9530

14001 Botts Rd.
Grandview, MO 64030
Ph: 816-761-4840

4400 E 60th Ave
Commerce City, CO 80022
Ph: 303-853-4840

Quote

Date	Quote #
6/20/2019	11477
Proposed Shipping Date	
9/15/19	
Terms	
Due on receipt	
Rep	
CRS	

City of Jefferson
220 N Chestnut
Jefferson, IA 50129

Here is our quotation on the goods named, subject to the conditions noted:

CONDITIONS: The prices and terms on this quotation are not subject to verbal changes or other agreements unless approved in writing by the Home Office of the Seller. Prices are based on costs and conditions existing on date of quotation and are subject to change by the Seller before final acceptance. All quotations and agreements are contingent upon strikes, accidents, fires, availability of materials and all other causes beyond our control. Typographical and stenographic errors subject to correction. Purchaser agrees to accept either overage or shortage not in excess of ten percent to be charged for pro-rata. Purchaser assumes liability for patent and copyright infringement when goods are made to Purchaser's specifications. When quotation specifies material to be furnished by the purchaser, ample allowance must be made for reasonable spoilage and material must be of suitable quality to facilitate efficient production.

Conditions not specifically stated herein shall be governed by established trade customs. Terms inconsistent with those stated herein which may appear on Purchaser's formal order will not be binding on the Seller.

TERMS: Equipment is due on receipt. Carts, Containers, Parts, & Service are Net 30 unless otherwise noted on your account. Balances over 30 days from date of invoice are subject to finance charges up to 1½% per month.

Qty	Item	Description	Price	Total
1	HV607	2019 International HV607 single axle chassis with 325 Horse Power Cummins B6.7 motor and Allison 3000 automatic transmission	75,867.00	75,867.00
1	20RLCOBRA	New Way Cobra 20 yd rear load packer with all standard features and the following: hot shift PTO with overspeed protection and pack on the go pump, reeving cylinder winch, kick bar, 2 perkins D6620 cart tippers, viper slide cylinders for faster cycle time, in cab controls for tailgate and eject, LED work lights in the hopper, integrated strobe lights in the upper tailgate, 5.6" color camera system with audio, mud flaps behind drive tires, white paint, standard one year warranty on the body and hydraulics, standard two year warranty on cylinders	77,853.00	77,853.00T
1	Outsourced Labor ...	20,000 lb lift axle with wheels and tires	7,500.00	7,500.00T
	Trade In	Customer Trade In Discount for 2007 Sterling with 20 yd New Way Cobra VIN: 2FZACGDJ47AY22762	-20,000.00	-20,000.00
		Customers Exempt From Sales Tax	0.00%	0.00

****Administrative Fee of \$150.00 will be added to all vehicle purchase transactions.****

Total	\$141,220.00
--------------	---------------------

TO CONFIRM ORDER, SIGN AND RETURN

X _____



3100 West 76th Street
 Davenport, IA 52806
 Ph: 563-391-4840

Elliott Sanitation Equip. Co.
 1245 Dawes Avenue
 Lincoln, NE 68521
 Ph: 402-474-4840

4000 SE Beisser Drive
 Grimes, IA 50111
 Ph: 515-986-4840
 Fx: 515-986-9530

14001 Botts Rd.
 Grandview, MO 64030
 Ph: 816-761-4840

4400 E 60th Ave
 Commerce City, CO 80022
 Ph: 303-853-4840

Quote

Date	Quote #
6/20/2019	11470
Proposed Shipping Date	
9/1/19	
Terms	
Due on receipt	
Rep	
CRS	

City of Jefferson
 220 N Chestnut
 Jefferson, IA 50129

Here is our quotation on the goods named, subject to the conditions noted:

CONDITIONS: The prices and terms on this quotation are not subject to verbal changes or other agreements unless approved in writing by the Home Office of the Seller. Prices are based on costs and conditions existing on date of quotation and are subject to change by the Seller before final acceptance. All quotations and agreements are contingent upon strikes, accidents, fires, availability of materials and all other causes beyond our control.

Typographical and stenographic errors subject to correction. Purchaser agrees to accept either overage or shortage not in excess of ten percent to be charged for pro-rata. Purchaser assumes liability for patent and copyright infringement when goods are made to Purchaser's specifications. When quotation specifies material to be furnished by the purchaser, ample allowance must be made for reasonable spoilage and material must be of suitable quality to facilitate efficient production.

Conditions not specifically stated herein shall be governed by established trade customs. Terms inconsistent with those stated herein which may appear on Purchaser's formal order will not be binding on the Seller.

TERMS: Equipment is due on receipt. Carts, Containers, Parts, & Service are Net 30 unless otherwise noted on your account. Balances over 30 days from date of invoice are subject to finance charges up to 1 1/2% per month.

Qty	Item	Description	Price	Total
1	520	2019 Peterbilt 520 tandem axle chassis with 380 Horse Power Paccar PX-9 motor and Allison 4500 RDS automatic transmission. New Way Sidewinder 31 yd automated side load packer with all standard features and the following: crusher panel, hopper access ladder, work light in the hopper and work light facing arm, integrated strobe lights in the upper and lower tailgate, 7" triple camera system with standard backup camera, camera in the hopper, and streetside camera facing rearward, remote grease bank for upper tailgate hinge pins, rocker switches under seat for arm operation from outside the cab, white paint, standard one year warranty on the body and hydraulics, and standard two year warranty on the cylinders	258,977.00	258,977.00
		*Price includes delivery to Jefferson and training		
		Customers Exempt From Sales Tax	0.00%	0.00

****Administrative Fee of \$150.00 will be added to all vehicle purchase transactions.****

Total	\$258,977.00
--------------	---------------------

TO CONFIRM ORDER, SIGN AND RETURN

X _____



3100 West 76th Street
 Davenport, IA 52806
 Ph: 563-391-4840

Elliott Sanitation Equip. Co.
 1245 Dawes Avenue
 Lincoln, NE 68521
 Ph: 402-474-4840

4000 SE Beisser Drive
 Grimes, IA 50111
 Ph: 515-986-4840
 Fx: 515-986-9530

14001 Botts Rd.
 Grandview, MO 64030
 Ph: 816-761-4840

4400 E 60th Ave
 Commerce City, CO 80022
 Ph: 303-853-4840

Quote

Date	Quote #
6/20/2019	11475
Proposed Shipping Date	
8/26/19	
Terms	
Due on receipt	
Rep	
CRS	

City of Jefferson
 220 N Chestnut
 Jefferson, IA 50129

Here is our quotation on the goods named, subject to the conditions noted:

CONDITIONS: The prices and terms on this quotation are not subject to verbal changes or other agreements unless approved in writing by the Home Office of the Seller. Prices are based on costs and conditions existing on date of quotation and are subject to change by the Seller before final acceptance. All quotations and agreements are contingent upon strikes, accidents, fires, availability of materials and all other causes beyond our control. Typographical and stenographic errors subject to correction. Purchaser agrees to accept either overage or shortage not in excess of ten percent to be charged for pro-rata. Purchaser assumes liability for patent and copyright infringement when goods are made to Purchaser's specifications. When quotation specifies material to be furnished by the purchaser, ample allowance must be made for reasonable spoilage and material must be of suitable quality to facilitate efficient production.

Conditions not specifically stated herein shall be governed by established trade customs. Terms inconsistent with those stated herein which may appear on Purchaser's formal order will not be binding on the Seller.

TERMS: Equipment is due on receipt. Carts, Containers, Parts, & Service are Net 30 unless otherwise noted on your account. Balances over 30 days from date of invoice are subject to finance charges up to 1½% per month.

Qty	Item	Description	Price	Total
1,482	USD95B.Blue	Schaefer USD95 B, 95 gallon B style cart with 12" plastic snap on wheels, City of Jefferson hot stamp on the side, serial number on the back, blue in color *Price includes assembly and distribution of carts to addresses provided by the City of Jefferson. Includes serial number tracking to pair cart serial number with a street address. Also includes attaching educational literature (provided by the City of Jefferson) to each cart as it is delivered	62.00	91,884.00T
300	USD65B.Blue	Schaefer USD65 B, 65 gallon B style cart with 10" plastic snap on wheels, City of Jefferson hot stamp on the side, serial number on the back, blue in color *Price includes assembly and distribution of carts to addresses provided by the City of Jefferson. Includes serial number tracking to pair cart serial number with a street address. Also includes attaching educational literature (provided by the City of Jefferson) to each cart as it is delivered	57.00	17,100.00T
1	Freight	Freight to Jefferson, IA	6,000.00	6,000.00
		Customers Exempt From Sales Tax	0.00%	0.00

****Administrative Fee of \$150.00 will be added to all vehicle purchase transactions.****

Total	\$114,984.00
--------------	---------------------

TO CONFIRM ORDER, SIGN AND RETURN

X _____

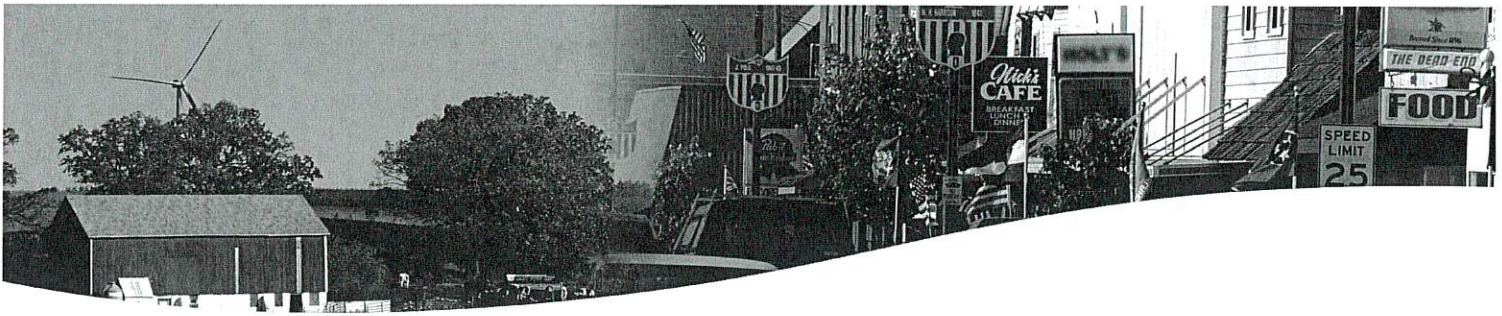

COMMUNITY ANNUAL PARTNERSHIP ASSESSMENT

Jefferson, IA 2018 Recap

Economic Development Support - \$900

- Assist in the economic development efforts in the community through program support of the Greene County Chamber and Greene County Development Corporation

Community Support - \$1,600

- Contribution through the AE Foundation:
 - Greene County Early Learning Center – STEM Summer Program
- Corporate Contribution – 2018 Jefferson RAGBRAI

Environmental Partnership Program Support - \$19,100

- Extension Greene County – Operation ReLeaf - 220 trees
- Branching Out - 38 trees

Energy Efficiency Participation and Impacts - \$89,680.69 Rebates Paid (up 156 %)

- Number of Rebates – 98
- Annual kWh Impact – 128,479
- Annual Therm Impact – 10,251

Community Infrastructure Investment - \$173,922

- Electric - \$123,393
- Natural Gas - \$50,529

Property Taxes - \$113,006

Employment

- Jefferson Operating Facility - 8

Please visit www.alliantenergy.com to learn more about Alliant Energy's community programs and services.



AGENDA

WATER/SEWER, STREET/SANITATION COMMITTEES TUESDAY, JUNE 18, 2019, 12:00 NOON JEFFERSON CITY HALL

I. SEWER

- A. Review of sewer connection issue at 503 E. Vest Street.
- B. Review of sewer rate increase

II. WATER

- A. Water usage report
- B. Review of water rate increase

III. STREETS

- A. Update of Children at Play sign on East McKinley Street.
- B. Discussion of Greenwood trail and East Entryway projects

IV. SANITATION/RECYCLE

- A. Timeline for trash truck replacement
- B. Waste collection report
- C. Recycling report

Jefferson Park & Recreation Commission AGENDA

Wednesday, June 19, 2019

12:00 pm Greene County Community Center

- I. Call to Order
- II. Roll Call
- III. Open Forum: This is a time for any concerned citizen to speak to the Board on an item that is not on the agenda. (Limit 3-5 minutes)
- IV.
- V. Approval of minutes for May
- VI. Approval of bills for May 15-June15
- VII. Old Business
 - a. Upgrading Computer System
 - b. Replacement of the Simplex Fire Alarm System
- VIII. New Business
 - a. Hiring a new director
 - b. Report from committee meeting with Wage and Means for salaries of the new director and assistant director
- IX. Reports
 - a. Wellness Report
 - b. Program Report
 - c. Directors Report
 - d. Parks Report
- X. Adjournment-Next meeting Wednesday, July 17, 2019 at noon at the GCCC