

AGENDA

COUNCIL MEETING
Tuesday, January 10, 2012
5:30 P.M.
CITY HALL COUNCIL CHAMBERS

- I. CALL TO ORDER:**
- II. OPEN FORUM:** This is a time for any concerned citizen to speak to the Council on an item that is not on the agenda.
- III. CONSENT ITEMS:**
 - A. Approval of December 13, 2011 minutes.
 - B. Approval of monthly bills.
- IV. NEW BUSINESS:**
 - A. Consider participation in development of Thomas Jefferson Gardens.
 - B. Approval of plat of survey for Edward and Denise Smith.
 - C. Third reading of ordinance amending Municipal Zoning Code, Section 165.13, Non-Conforming Structures.
 - D. Approval of pay estimate No. 3 (Final) to A.M. Cohron and Son Inc. for Jackson Bridge repairs.
 - E. Resolution setting date for hearing on General Obligation Refunding Loan Agreement.
 - F. Appointment of Police Chief.
 - G. Consider approval of hiring police officer.
 - H. Annual appointments by the Mayor.
- V. REPORTS:**
 - A. Mayor
 - B. Engineer
 - C. Attorney
 - D. City Administrator
 - E. Council & Committees
- VI. ADJOURN.**

AGENDA SUMMARY

DATE 1/10/12

NEW BUSINESS

- A. **Consider participation in development of Thomas Jefferson Gardens.** At the 12-13-11 Council meeting, the Council asked for an update on the project.
- B. **Approval of plat of survey for Edward and Denise Smith.** Attached is a plat of survey map to transfer the west 30 feet of Lots 175 and 176, Block 24 to Thomas Jefferson Gardens Foundation.
- C. **Third reading of ordinance amending Municipal Zoning Code, Section 165.13, Non-Conforming Structures.**
- D. **Approval of pay estimate No. 3 (Final) to A.M. Cohron and Son Inc. for Jackson Bridge repairs.** This would be the final payment on the bridge repairs in the amount of \$3,895.90.
- E. **Resolution setting date for hearing on General Obligation Refunding Loan Agreement.** At the September 27, 2011 Council meeting, the Council discussed the reissuance of a \$985,000 outstanding General Obligation Bond. Because of current interest rates, the City could potentially save about \$42,000 by reissuing the bonds for the remaining three years.
- F. **Appointment of Police Chief.**
- G. **Consider approval of hiring police officer.** Dave Morland is recommending to hire Kyle DeMoss as a full time officer.
- H. **Annual appointments by the Mayor.**

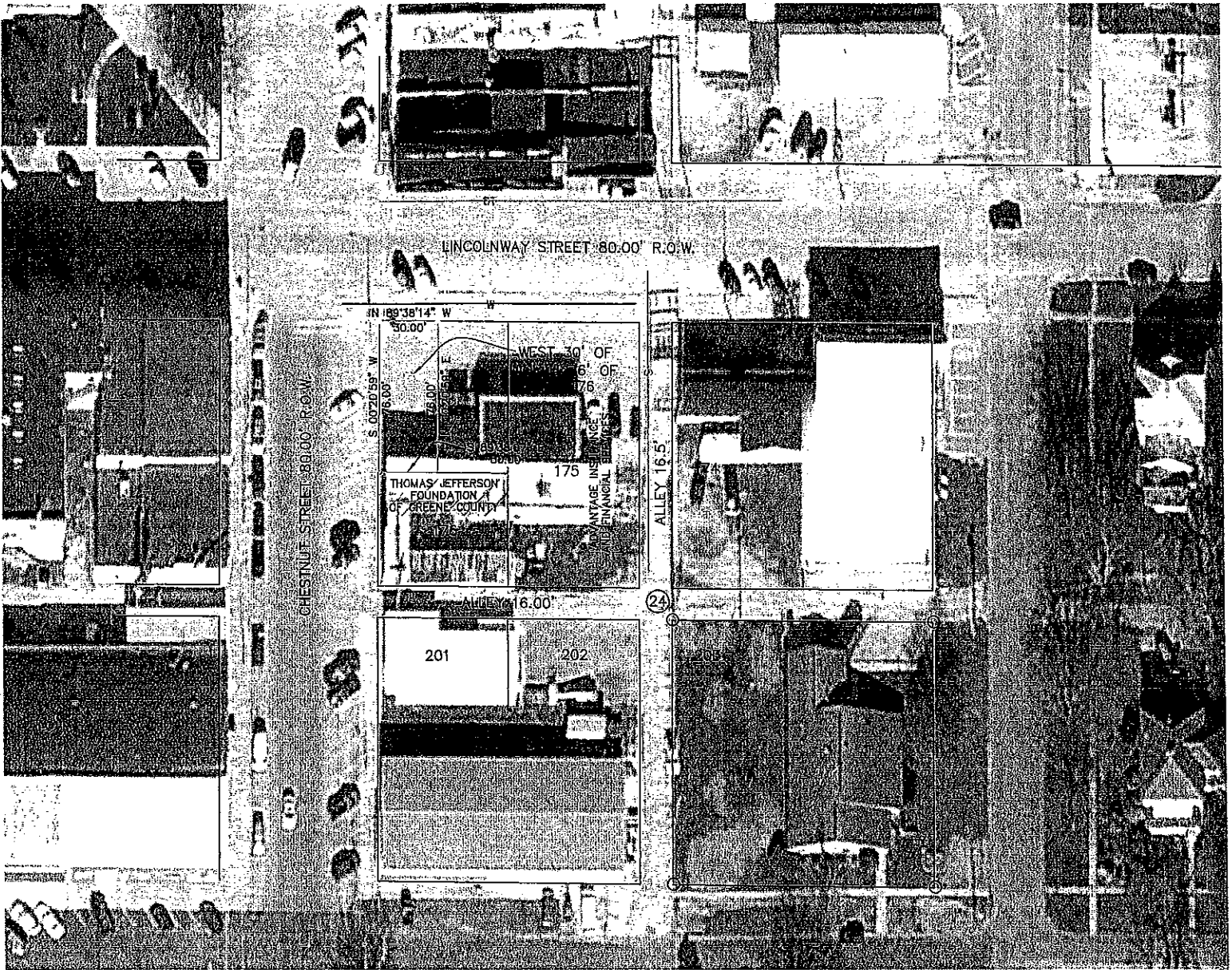

GENERAL NOTES:

1. CITY OF JEFFERSON UTILITY LINES (SANITARY SEWER, STORM SEWER, AND WATER) ARE ONLY GENERALLY LOCATED. UTILITY SERVICES BY OTHERS ARE NOT SHOWN. "ONE CALL" SHOULD BE CONTACTED PRIOR TO ANY CONSTRUCTION ACTIVITIES.
2. AERIAL PHOTO IS ONLY APPROXIMATED TO PROPERTY LINES.



CITY UTILITY LEGEND

- S — SANITARY SEWER
- ST — STORM SEWER
- W — WATER MAIN
- — — — — EASEMENT

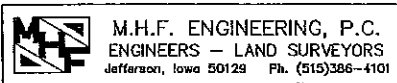

M.H.F. ENGINEERING, P.C.
 ENGINEERS - LAND SURVEYORS
 Jefferson, Iowa 50129 Ph. (515)386-4101

WARDER C. HILLHOUSE, JR. MHF ENGINEERING P.C. 300 W. MCKINLEY JEFFERSON, IA. (515)386-4101



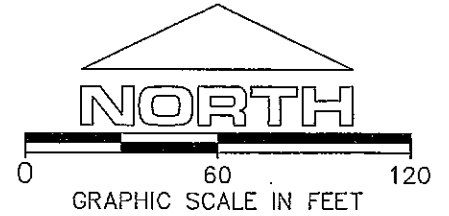



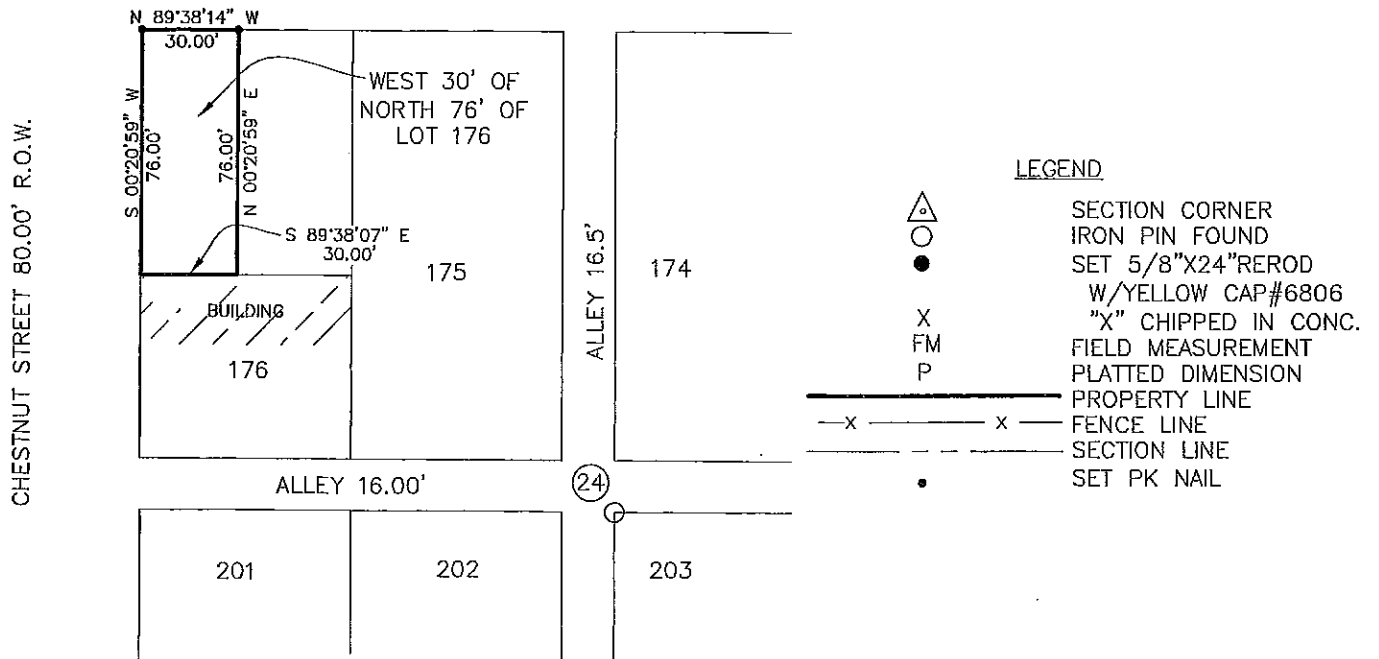



PLAT OF SURVEY
WEST 30' OF
NORTH 76' LOT 176 BLK 24 O.T.
JEFFERSON, GREENE COUNTY, IOWA



LINCOLNWAY STREET 80.00' R.O.W.

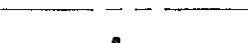

LEGEND

-  SECTION CORNER
-  IRON PIN FOUND
-  SET 5/8"X24"REROD
W/YELLOW CAP#6806
-  "X" CHIPPED IN CONC.
-  FIELD MEASUREMENT
-  PLATTED DIMENSION
-  PROPERTY LINE
-  FENCE LINE
-  SECTION LINE
-  SET PK NAIL

SURVEY REQUESTED BY: TOM POLKING

OWNER: ADVANTAGE INSURANCE AND FINANCIAL SERVICES

FIELD NOTES:

THE WEST 30.00 FEET OF THE NORTH 76.00 FEET OF LOT 176 IN BLOCK 24 OF THE ORIGINAL TOWN OF JEFFERSON, GREENE COUNTY, IOWA. SUBJECT TO EASEMENTS APPARENT OR OF RECORD.